

Friction Block Wear Control

Function

All brakes can be supplied on request with an electrical wear indicator which signals the limit of the friction block wear. The control lamp in the wear monitor indicates when the friction blocks need to be replaced. In addition, the output relay can trigger a signal in the central control station.

Friction Blocks with Signal Cable

Friction blocks with signal cable are used to monitor wear. Cable length 25 cm with plug connection.

Wear indicator

- Housing: Makrolon
- Insulation: IP 65
- Colour: Grey, RAL 7035
- Temperature range: -50° C to 60° C
- Output relay: (Changer)
Reverser
max. 6 A, max. 220 V

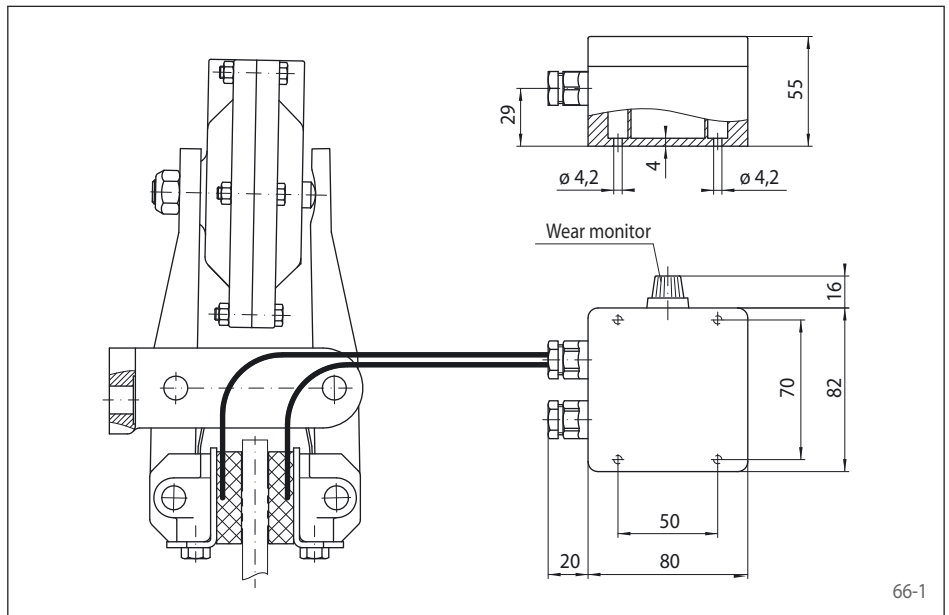

Article Number for supply voltage	
24 V DC	220 V AC, 50 Hz
3511.000.001.B024VG	3511.000.001.B220VW

Universal Transformer

The Universal Transformer is used to operate a DH 012 FEM or DV 020 FEM Brake Caliper.

Output: 0,25 kVA

Primary voltages:

200 V, 220 V, 240 V, 260 V, 280 V, 300 V, 310 V, 330 V, 350 V, 360 V, 380 V, 400 V, 420 V, 440 V, 480 V, 500 V, 530 V and 550 V

Secondary voltages:

115 V or 230 V

The Universal Transformer is manufactured in accordance with EN 61558 / VDE 0570:

- Clamps in accordance with VDGB-4
- Insulation class T40/E
- Safety class 1

Article Number: 3503.000.001.000000

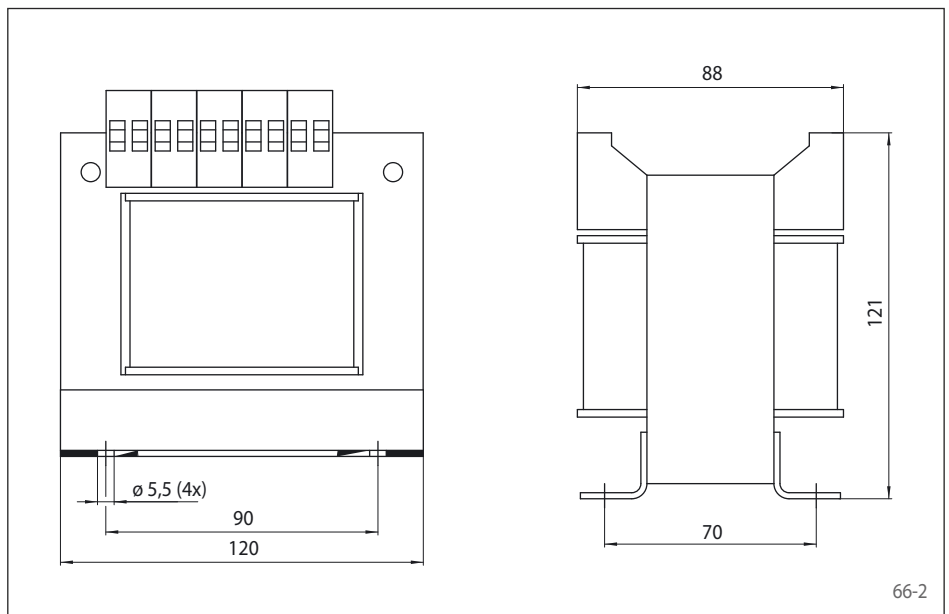

Any questions? Please contact us.